

Operating instructions

Digital indicator, model DI32-1

EN

EAC



Digital indicator, model DI32-1

EN	Operating instructions model DI32-1	Page	3 - 70
-----------	--	-------------	---------------

Further languages can be found on www.wika.com

© 2015 WIKA Alexander Wiegand SE & Co. KG

All rights reserved.

WIKA® is a registered trademark in various countries.

Contents

1. General information	6
2. Design and function	7
2.1 Overview	7
2.2 Description	8
2.3 Scope of delivery	8
3. Safety	9
3.1 Explanation of symbols	9
3.2 Intended use	9
3.3 Improper use	10
3.4 Personnel qualification	10
3.5 Labelling, safety marks	11
4. Transport, packaging and storage	12
5. Commissioning	13
5.1 Requirements for the installation location	13
5.2 Mounting	13
5.3 Electrical connection	14
5.4 Switching on the digital indicator	14
5.5 Connection examples	15
6. Operation	20
6.1 Key functions	20
6.2 Menu navigation	20
6.3 Setting the numeric values	21
6.4 Accessing and exiting programming mode	21
7. Voltage or current measurement	22
7.1 Selecting the input signal and measuring range	22
7.2 Setting the indication range	23
7.3 Selecting the number of decimal places	23
7.4 Scaling the input signal	24
7.5 Setting the offset adjustment (TARE)	24
7.6 Setting the zero point suppression	24
7.7 Select the overrun and underrun behaviour	25
7.8 Linearising the sensor values	26
7.9 Menu tree	27

8. Temperature measurement	29
8.1 Selecting measuring element and measuring range	29
8.2 Select unit	30
8.3 Setting the impedance matching	30
8.4 Menu tree	31
9. Frequency measurement	32
9.1 Selecting the input signal	32
9.2 Selecting triggering of the pulse input	32
9.3 Select frequency range	33
9.4 Selecting pulse length limiting	33
9.5 Setting the indication range	34
9.6 Selecting the number of decimal places	34
9.7 Scaling the pulse signals	35
9.8 Setting the offset adjustment (TARE)	35
9.9 Linearising the sensor values	36
9.10 Menu tree	37
10. Rotational speed measurement	39
10.1 Selecting the input signal	39
10.2 Selecting triggering of the pulse input	39
10.3 Selecting pulse length limiting	40
10.4 Setting pulses per rotation	40
10.5 Selecting the time base	41
10.6 Selecting the number of decimal places	41
10.7 Menu tree	42
11. Up/Down counter	43
11.1 Selecting an up or down counter	43
11.2 Selecting triggering of the pulse input	43
11.3 Selecting the counter basis	44
11.4 Setting the edge control	44
11.5 Setting the prescaler	45
11.6 Selecting pulse length limiting	45
11.7 Setting the upper indication value and upper pulse count value	46
11.8 Selecting the number of decimal places	46
11.9 Menu tree	47

12. General settings	49
12.1 Setting the measuring time.	49
12.2 Setting the moving average determination	49
12.3 Limiting the indication range	50
12.4 Assigning key functions	50
12.5 Selecting display blinking	51
12.6 Menu tree	52
13. Switching outputs	53
13.1 Selecting the switching function.	53
13.2 Setting a switching window (window function)	54
13.3 Selecting switch behaviour for limit value errors.	54
13.4 Selecting switch behaviour.	55
13.5 Setting the switching threshold	55
13.6 Setting the hysteresis	56
13.7 Setting the switch-off delay	56
13.8 Setting the switch-on delay	56
13.9 Menu tree	57
14. Password protection	60
14.1 Setting the password	60
14.2 Activating/deactivating the password protection	60
14.3 Menu tree	61
15. Factory settings	62
15.1 Restoring factory settings.	62
15.2 Overview of the factory settings.	62
16. Faults	64
17. Maintenance and cleaning	65
18. Dismounting, return and disposal	66
19. Specifications	67
Appendix: EC declaration of conformity	70

Declarations of conformity can be found online at www.wika.com

1. General information

- The digital indicator described in these operating instructions has been designed and manufactured using state-of-the-art technology. All components are subject to stringent quality and environmental criteria during production. Our management systems are certified to ISO 9001 and ISO 14001.
- These operating instructions contain important information on handling the instrument. Working safely requires that all safety instructions and work instructions are observed.
- Observe the relevant local accident prevention regulations and general safety regulations for the instrument's range of use.
- The operating instructions are part of the product and must be kept in the immediate vicinity of the instrument and readily accessible to skilled personnel at any time. Pass the operating instructions onto the next operator or owner of the instrument.
- Skilled personnel must have carefully read and understood the operating instructions prior to beginning any work.
- The general terms and conditions contained in the sales documentation shall apply.
- Subject to technical modifications.
- Further information:
 - Internet address: www.wika.de / www.wika.com
 - Relevant data sheet: AC 80.13
 - Application consultant: Tel.: +49 9372 132-0
Fax: +49 9372 132-406
info@wika.de

2. Design and function

2. Design and function

2.1 Overview



EN

	Designation	Description
①	[⊛] key	Programming mode is accessed Changes to a deeper parameter level
②	[▼] key	MIN memory is accessed Changes lower limit values Changes between parameters Changes parameter values
③	[▲] key	MAX memory is accessed Changes lower limit values Changes between parameters Changes parameter values
④	Switch point display	Displays the status of the switching outputs
⑤	Mounting element with clamping screws	Used for fixing
⑥	7-segment display	Displays measured values, program numbers or parameters
⑦	Product label	Contains product information

2.2 Description

The DI32-1 is a 4-digit digital indicator for the measurement of different measurement signals (voltage, current, temperature and frequency). The configuration is made via three front keys. Password protection prevents unwanted changes to the parameters.

With the two semiconductor switching outputs, limits can be monitored and signalled to a control room. The electrical connections are made at the rear via plug-in terminals.

Functions

- Retrieval of the MIN/MAX values
- Tare function
- Averaging function
- Adjustable switching thresholds
- Linearisation of the measuring input

2.3 Scope of delivery

- Digital indicator
- Sealing
- 2 mounting elements
- Operating instructions

Cross-check scope of delivery with delivery note.

3. Safety

3.1 Explanation of symbols

**WARNING!**

... indicates a potentially dangerous situation that can result in serious injury or death, if not avoided.

**CAUTION!**

... indicates a potentially dangerous situation that can result in light injuries or damage to equipment or the environment, if not avoided.

**Information**

... points out useful tips, recommendations and information for efficient and trouble-free operation.

3.2 Intended use

The DI32-1 digital indicator is designed for the evaluation and display of sensor signals. With the switching outputs, it is possible to realise simple control functions.

The digital indicator is not permitted to be used in hazardous areas.

Only use the digital indicator in applications that lie within its technical performance limits (e.g. max. ambient temperature).

→ Performance limits see chapter 19 “Specifications”.

The instrument has been designed and built solely for the intended use described here, and may only be used accordingly.

The manufacturer shall not be liable for claims of any type based on operation contrary to the intended use.

3.3 Improper use



WARNING!

Injuries through improper use

Improper use of the instrument can lead to hazardous situations and injuries.

- ▶ Refrain from unauthorised modifications to the instrument.
- ▶ Do not use the instrument within hazardous areas.

Any use beyond or different to the intended use is considered as improper use.

3.4 Personnel qualification



WARNING!

Risk of injury should qualification be insufficient

Improper handling can result in considerable injury and damage to equipment.

- ▶ The activities described in these operating instructions may only be carried out by personnel who have the qualifications described below.

Skilled electrical personnel

Skilled electrical personnel are understood to be personnel who, based on their technical training, know-how and experience as well as their knowledge of country-specific regulations, current standards and directives, are capable of carrying out work on electrical systems and independently recognising and avoiding potential hazards. The skilled electrical personnel have been specifically trained for the work environment they are working in and know the relevant standards and regulations. The skilled electrical personnel must comply with current legal accident prevention regulations.

3. Safety

3.5 Labelling, safety marks

Product label

The product label is located on the upper side of the digital indicator.

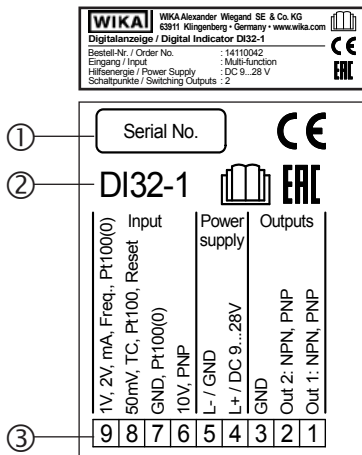

- ① Serial number
- ② Model
- ③ Pin assignment

Symbols



Before mounting and commissioning the instrument, ensure you read the operating instructions!

4. Transport, packaging and storage

4.1 Transport

Check the digital indicator for any damage that may have been caused by transport. Obvious damage must be reported immediately.

EN



CAUTION!

Damage through improper transport

With improper transport, damage to property can occur.

- ▶ When unloading packed goods upon delivery as well as during internal transport, proceed carefully and observe the symbols on the packaging.
- ▶ With internal transport, observe the instructions in chapter 5.2 "Packaging and storage".

4.2 Packaging and storage

Do not remove packaging until just before mounting.

Keep the packaging as it will provide optimum protection during transport (e.g. change in installation site, sending for repair).

Permissible conditions at the place of storage:

- Storage temperature: -30 ... +70 °C
- Humidity: 0 ... 85 % relative humidity (no condensation)

Avoid exposure to the following factors:

- Direct sunlight or proximity to hot objects
- Mechanical vibration, mechanical shock (putting it down hard)
- Soot, vapour, dust and corrosive gases

Store the digital indicator in its original packaging in a location that fulfils the conditions listed above. If the original packaging is not available, pack and store the instrument as described below:

1. Wrap the instrument in a plastic film.
2. Place the instrument, along with the shock-absorbent material, in the packaging.

5. Commissioning

If the instrument is transported from a cold into a warm environment, the formation of condensation may result in instrument malfunction. Before putting it into operation, wait for the instrument temperature and the room temperature to equalise.

EN

5.1 Requirements for the installation location

- In the vicinity there should be no magnetic or electrical fields, e.g. from transformers, radio-telephones or electrostatic discharges.
- In the vicinity there should be no strong heat sources. The permissible operating temperature must not be exceeded (max. 50 °C).

5.2 Mounting

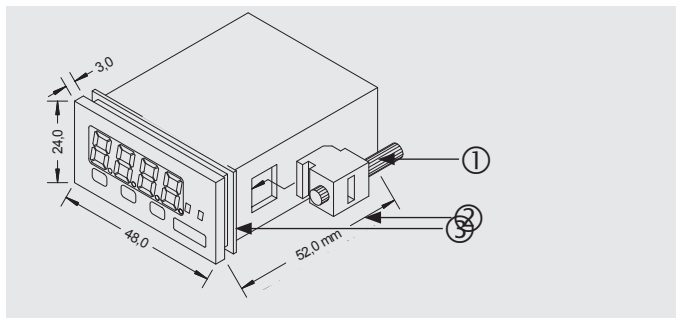

- ① Mounting element
- ② Clamping screw
- ③ Sealing

Cutting out the control panel

- Control panel thickness max. 3 mm
- Panel cutout $45.0^{+0.6} \times 22.2^{+0.3}$ mm

5. Commissioning

Installing the digital indicator

1. Remove the mounting elements.
2. Slide the seal over the digital indicator.
3. Slide the digital indicator into the control panel from the front.
Check the seal is properly seated.
4. Lock the mounting elements into place and tighten the clamping screws (max. 0.1 Nm).

5.3 Electrical connection

Notes on installation

- Protect the power supply with a slow fuse of max. 2 A.
- Route the signal input lines and signal output lines separately.
- Route outward and return lines side-by-side.
- Galvanically isolated potentials must be connected to a suitable point (e.g. earth or plant ground).
- For high-accuracy requirements and small measurement signals, the sensor wires must be shielded and twisted. The shield should be connected at one end only to a suitable equipotential bonding (e.g. measurement ground).
- Avoid electrostatic discharges in the area of the terminals.

Terminal configuration

9-pin terminal block

Signal inputs				Power supply (not galvanically isolated)		Switch points (not galvanically isolated)		
9	8	7	6	5	4	3	2	1
DC 1 V DC 2 V mA Frequency Pt100 Pt1000	50 mV TC Pt100 Reset	GND Pt100 Pt1000	DC 10 V Freq.PNP	U-	U+	GND	OUT2 NPN PNP	OUT1 NPN PNP

→ For further information see chapter 19 "Specifications"

5.4 Switching on the digital indicator

- ▶ Connect the power supply.
 - » Segment test is carried out. Check the correct operation of all LEDs
 - » Software type and software version are displayed.
 - » Digital indicator is ready for operation.

5.5 Connection examples

5.5.1 Current and voltage measurement

2-wire sensor, 4 ... 20 mA

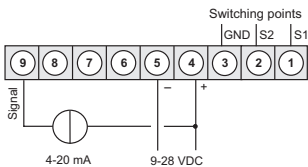

2-wire sensor, 4 ... 20 mA with external supply

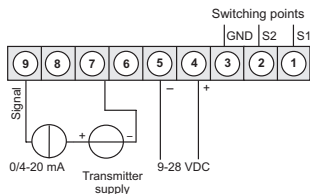

3-wire sensor, 4 ... 20 mA

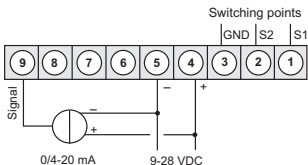

3-wire sensor, 4 ... 20 mA with external supply

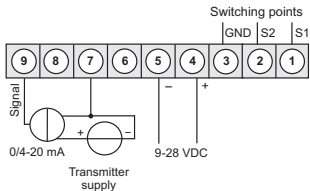

3-wire sensor, 0 ... 1/2 ... 10 V

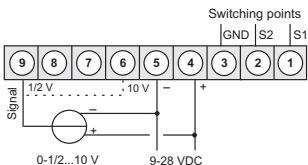

3-wire sensor, 0 ... 1/2 ... 10 V with external supply

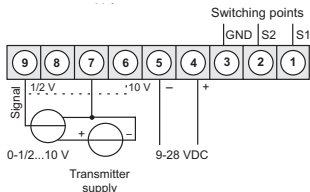

5. Commissioning

4-wire sensor, 0 ... 1/2 ... 10 V, 50 mV

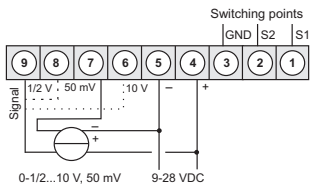

4-wire sensor, 0 ... 1/2 ... 10 V, 50 mV, with external supply

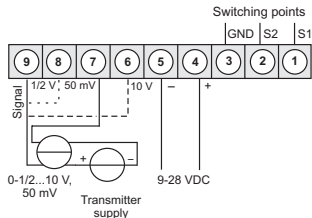

5.5.2 Temperature measurement

Pt100, 3-wire

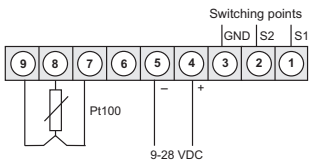

Pt1000, 2-wire

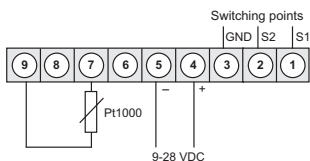

Thermocouple

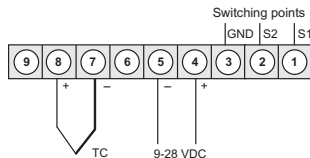

5. Commissioning

5.5.3 Frequency and rotational speed measurement

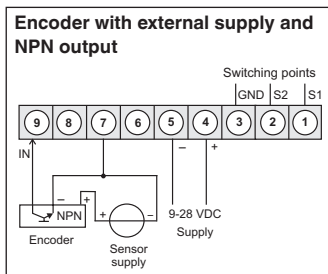
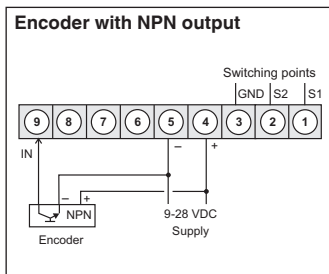
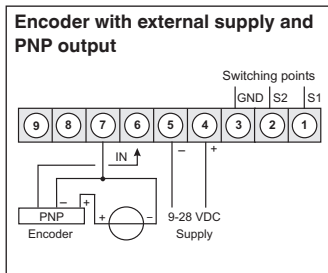
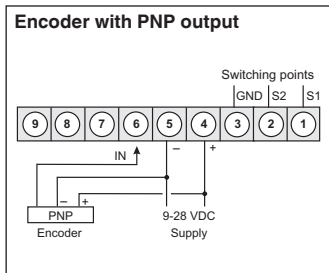
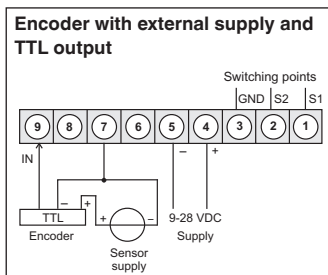
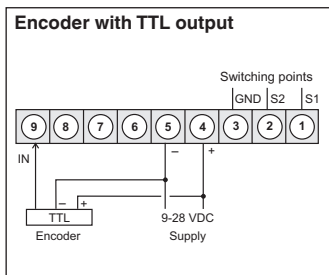

Encoder with NPN output and external resistor

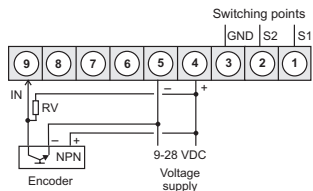

Encoder with external supply, NPN output and external resistor

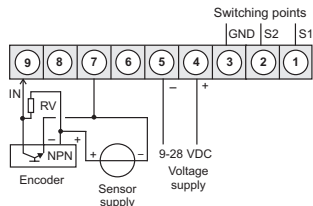

Encoder with PNP output and external resistor connection

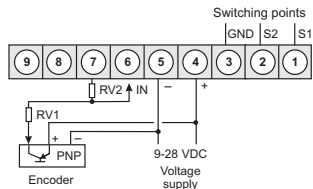

Encoder with external supply, PNP output and external resistor connection

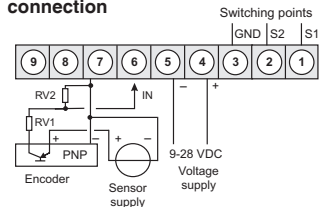

5.5.4 Counter

Manual reset with external button

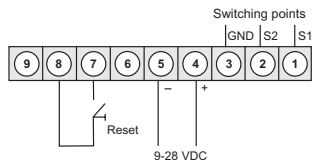

Automatic reset with output 2 and manual reset with external button

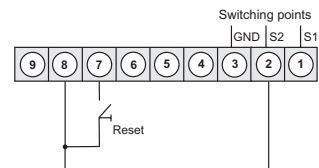

5. Commissioning

5.5.5 Switch points

NPN output, low side

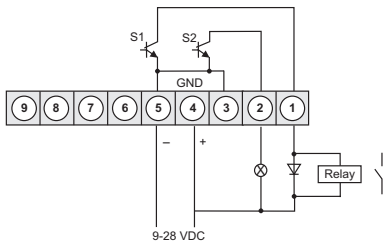

PNP output, high side

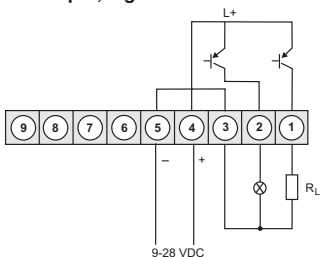

Push-pull output, low side and high side

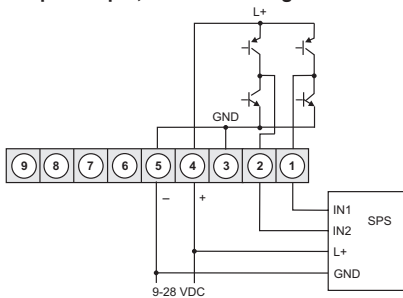

6. Operation

6.1 Key functions

Key	Function
[☼] key	Programming mode is accessed. Changes to a deeper menu level. Settings confirmed.
[▼] key	Accesses MIN memory (settable via programming). Changes lower limit values (settable via programming). Navigates downwards in the menu. Lowers numerical values.
[▲] key	Accesses MAX memory (settable via programming). Changes lower limit values (settable via programming). Navigates upwards in the menu. Increases numerical values.

6.2 Menu navigation

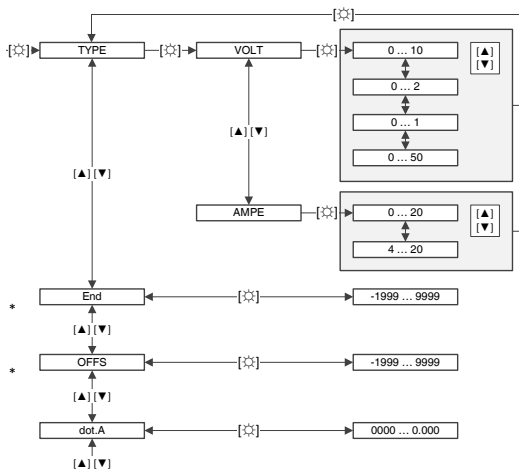

6. Operation

6.3 Setting the numeric values

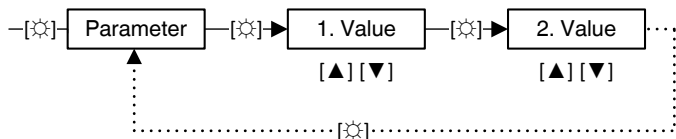

EN

6.4 Accessing and exiting programming mode

Accessing

- ▶ Press [⊛].
 - » "TYPE" will be shown in the display.

Exit

The digital indicator reverts to operating mode automatically after 10 seconds of inactivity. The entered settings will be saved.

7. Voltage or current measurement

7. Voltage or current measurement

This chapter leads you through the parameters, step by step. Therefore, the sub-chapters should be worked through in sequence. Dashed lines in the diagrams indicate parameters that are skipped.

EN

→ Complete menu tree from page 27

7.1 Selecting the input signal and measuring range

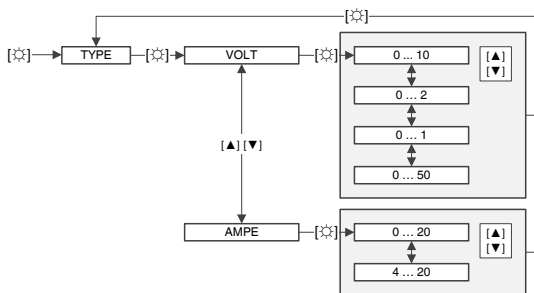

Parameter	Description
0 - 10	DC 0 ... 10 V
0 - 2	DC 0 ... 2 V
0 - 1	DC 0 ... 1 V
0 - 50	DC 0 ... 50 mV
0 - 20	0 ... 20 mA
4 - 20	4 ... 20 mA

7. Voltage or current measurement

7.2 Setting the indication range

With this value pair, the measurement signal is assigned the desired indication value.

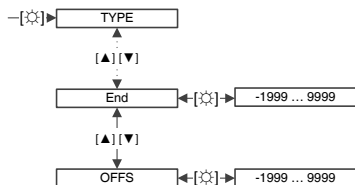

Parameter	Description	Setting range
End	End of measuring range	-1999 ... 9999
OFFS	Start of measuring range	-1999 ... 9999

7.3 Selecting the number of decimal places

Specifies the number of decimal places that are displayed on the screen. This parameter has no influence on the scaling or the indication value.

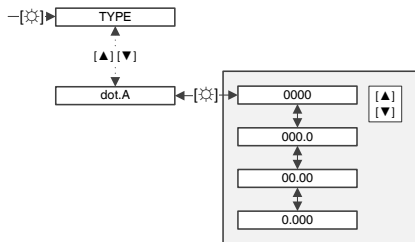

7. Voltage or current measurement

7.4 Scaling the input signal

With this value pair, the start of the measuring range and the end of the measuring range can be scaled. The measurement signal must not be applied.

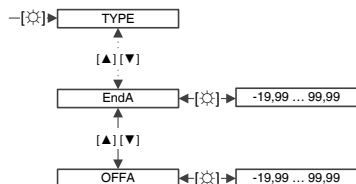

Parameter	Description	Setting range
EndA	End of measuring range	-19.99 ... 99.99
OFFA	Start of measuring range	-19.99 ... 99.99

7.5 Setting the offset adjustment (TARE)

The characteristic curve of the input signal is shifted in parallel by the offset value.

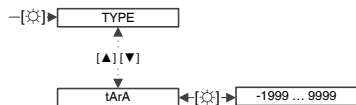

7.6 Setting the zero point suppression

A defined indication range is represented by 0000. With this function a fluctuating indication of the zero point is avoided.

Example: Parameter 10 = indication range -10 ... +10 is displayed as 0000.

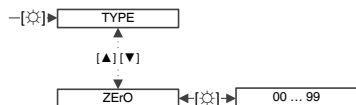

7. Voltage or current measurement

7.7 Select the overrun and underrun behaviour

Overrun is indicated with 4 bars above.

Underrun is indicated with 4 bars below.

The exception to this is the 4 ... 20 mA input signal, where a measured value smaller than 1 mA is already indicated as an underrun. This signals a sensor failure.

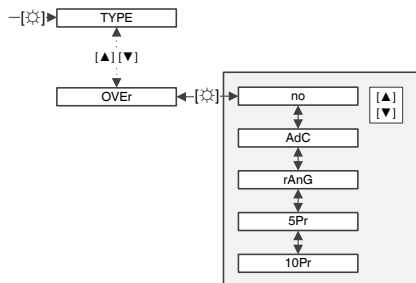

Parameter	Description
no	If the indication range is left, the display will remain on the smallest value (dl.Lo) or the highest value (dl.HI).
AdC	With the display range being exceeded above or below the limits (dl.Lo/dl.HI), over- or underrun will be displayed.
rAnG	With the measuring range being exceeded above or below the limits (EnD/OFFS), over- or underrun will be displayed. The indication range and transducer range are monitored additionally.
5Pr	The input signal is monitored to $\pm 5\%$ of the measuring range. The indication range is also monitored.
10Pr	The input signal is monitored to $\pm 10\%$ of the measuring range. The indication range is also monitored.

7. Voltage or current measurement

7.8 Linearising the sensor values

Setting the number of programmable points

In addition to the lower and upper indication values, an additional 5 programmable points can be defined. Only activated programmable point parameters will be displayed (dIS.1 ... 5, InP.1 ... 5).

EN

Parameter	Description	Setting range
SPC.A	Number of programmable points	0 ... 5

Setting analogue and indication values for programmable points

The value stored under "dIS" will be shown on the display, when it matches the sensor signal defined under "InP". The values must be parameterised in increasing order.

Parameter	Description	Setting range
dIS.1	Indication value for programmable point 1	-1999 ... 9999
InP.1	Analogue value for programmable point 1	-1999 ... 9999
dIS.2	Indication value for programmable point 2	-1999 ... 9999
InP.2	Analogue value for programmable point 2	-1999 ... 9999
dIS.3	Indication value for programmable point 3	-1999 ... 9999
InP.3	Analogue value for programmable point 3	-1999 ... 9999
dIS.4	Indication value for programmable point 4	-1999 ... 9999
InP.4	Analogue value for programmable point 4	-1999 ... 9999
dIS.5	Indication value for programmable point 5	-1999 ... 9999
InP.5	Analogue value for programmable point 4	-1999 ... 9999

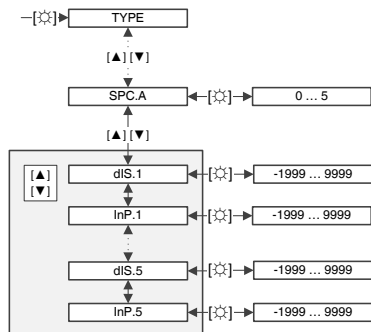

7. Voltage or current measurement

7.9 Menu tree

* Pflicht-Parameter

Eingangssignal *

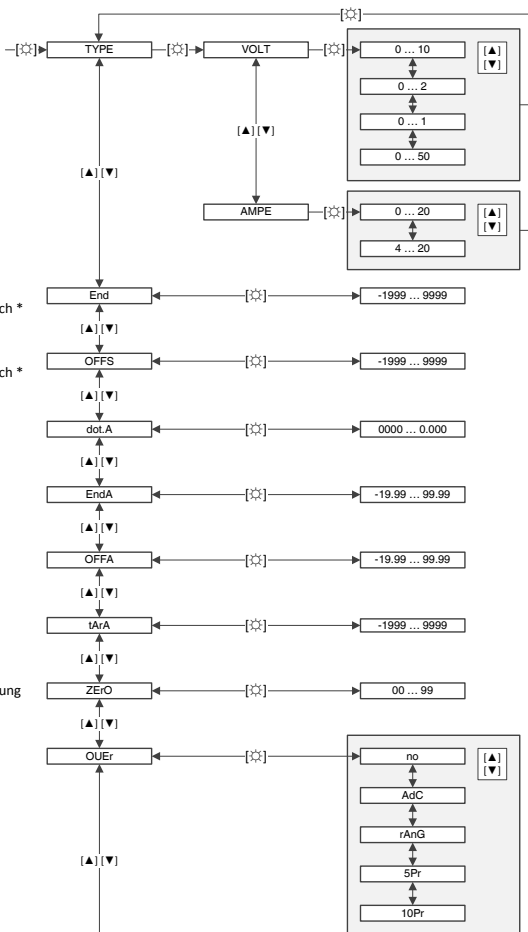

EN

7. Voltage or current measurement

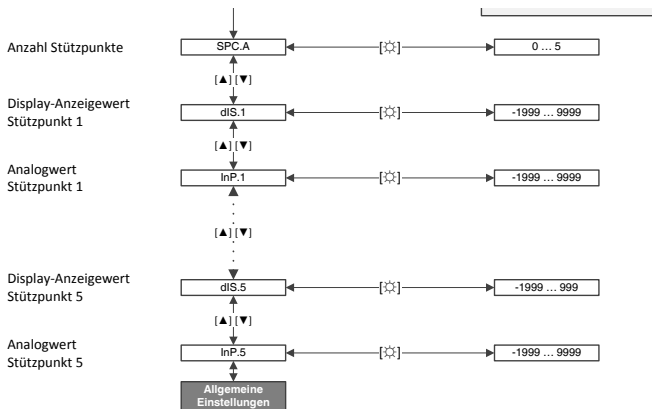

EN

14122699.02 10/2016 EN

8. Temperature measurement

This chapter leads you through the parameters, step by step. Therefore, the sub-chapters should be worked through in sequence. Dashed lines in the diagrams indicate parameters that are skipped.

→ Complete menu tree from page 31

8.1 Selecting measuring element and measuring range

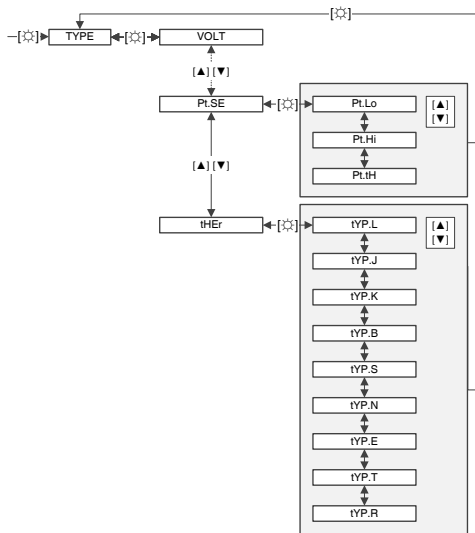

Parameter	Description	Parameter	Description
Pt.Lo	Pt100 3-wire -50 ... +200 °C	tYP.B	Thermocouple type B
Pt.Hi	Pt100 3-wire -200 ... +850 °C	tYP.S	Thermocouple type S
Pt.tH	Pt1000 2-wire -200 ... +850 °C	tYP.N	Thermocouple type N
tYP.L	Thermocouple type L	tYP.E	Thermocouple type E
tYP.J	Thermocouple type J	tYP.T	Thermocouple type T
tYP.K	Thermocouple type K	tYP.R	Thermocouple type R

8. Temperature measurement

8.2 Select unit

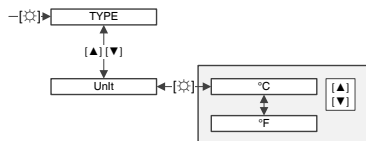

8.3 Setting the impedance matching

With a temperature measurement, an error can occur as a result of the wire resistance. This measuring error can be corrected in the following ranges:

- Measurement in °C: -20.0 ... +20.0
- Measurement in °F: -36 ... +36

If the unit is changed under "Unit", the value under "OFFS" will be converted and rounded.

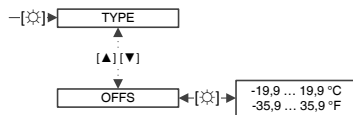

8. Temperature measurement

8.4 Menu tree

* Pflicht-Parameter

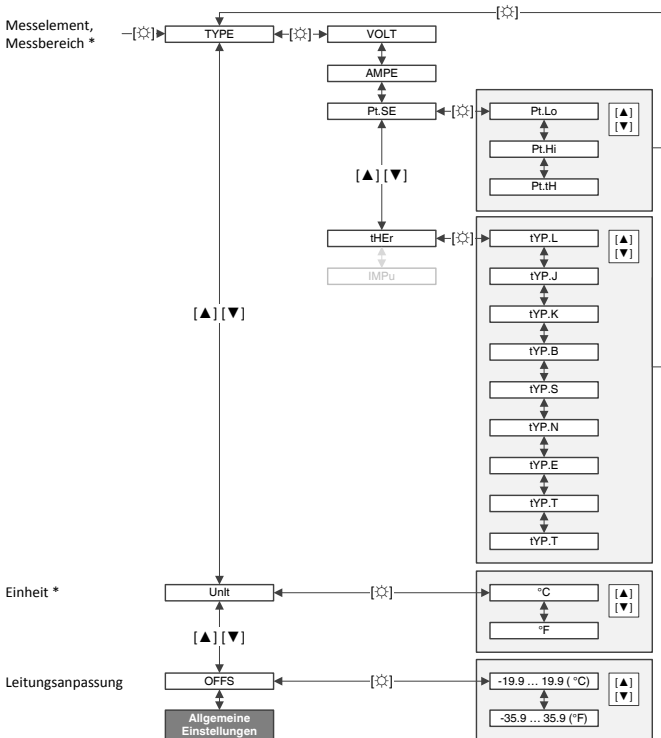

EN

9. Frequency measurement

9. Frequency measurement

This chapter leads you through the parameters, step by step. Therefore, the sub-chapters should be worked through in sequence. Dashed lines in the diagrams indicate parameters that are skipped.

→ Complete menu tree from page 37

9.1 Selecting the input signal

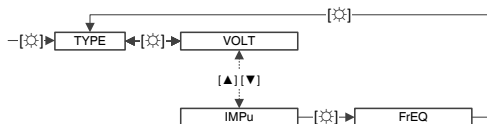

9.2 Selecting triggering of the pulse input

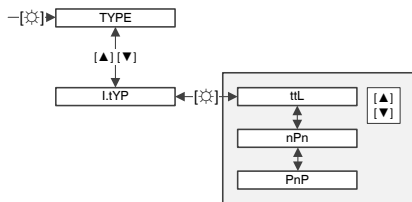

Parameter	Description
ttL	Active TTL signals 0.8 ... 2 V
nPn	Passive switch contact. Internal pull-up is switched.
PnP	Active sensor output. Internal pull-down is switched.

9. Frequency measurement

9.3 Select frequency range

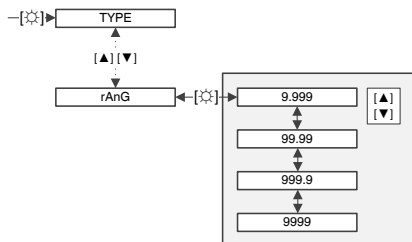

Parameter	Description
9.999	0 ... 9.999 Hz (automatic software filter at 100 Hz/5 ms)
99.99	0 ... 99.99 Hz (automatic software filter at 500 Hz/5 ms)
999.9	0 ... 999.9 Hz
9999	0 ... 9999 Hz (approximately 10 kHz)

9.4 Selecting pulse length limiting

Debounces mechanical contacts via the filter frequency.

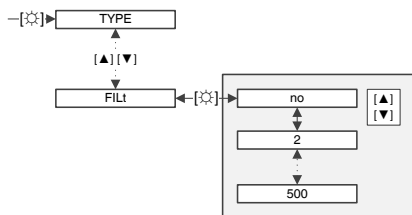

Parameter	Description
no	No evaluation of the pulse length.
2	2 Hz with a pulse-duty factor of 1:1 (minimum pulse length 250 ms)
5	5 Hz with a pulse-duty factor of 1:1 (minimum pulse length 100 ms)
10	10 Hz with a pulse-duty factor of 1:1 (minimum pulse length 50 ms)
20	20 Hz with a pulse-duty factor of 1:1 (minimum pulse length 25 ms)
50	50 Hz with a pulse-duty factor of 1:1 (minimum pulse length 10 ms)
100	100 Hz with a pulse-duty factor of 1:1 (minimum pulse length 5 ms)
500	500 Hz with a pulse-duty factor of 1:1 (minimum pulse length 1 ms)

9. Frequency measurement

9.5 Setting the indication range

With this value pair, the measurement signal is assigned the desired indication value.

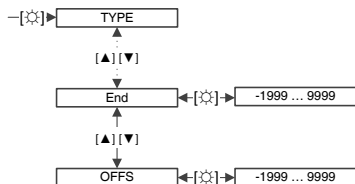

Parameter	Description	Setting range
End	End of measuring range	-1999 ... 9999
OFFS	Start of measuring range	-1999 ... 9999

9.6 Selecting the number of decimal places

Specifies the number of decimal places that are displayed on the screen. This parameter has no influence on the scaling or the indication value.

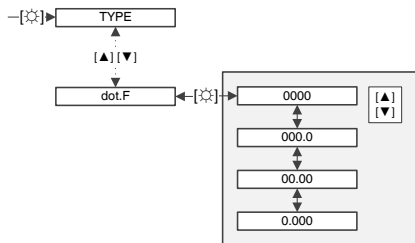

9. Frequency measurement

9.7 Scaling the pulse signals

With this value pair, the start of the measuring range and the end of the measuring range can be scaled. The measurement signal must not be applied.

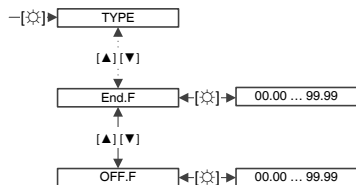

Parameter	Description	Setting range
End.F	End of measuring range	00.00 ... 99.99
OFF.F	Start of measuring range	00.00 ... 99.99

9.8 Setting the offset adjustment (TARE)

The characteristic curve of the input signal is shifted in parallel by the offset value.

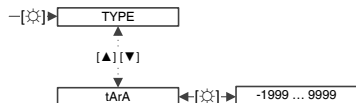

9. Frequency measurement

9.9 Linearising the sensor values

Setting the number of programmable points

In addition to the lower and upper indication values, an additional 5 programmable points can be defined. Only activated programmable point parameters will be displayed (dIS.1 ... 5, InP.1 ... 5).

Parameter	Description	Setting range
SPC.F	Number of programmable points	0 ... 5

Setting analogue and indication values for programmable points

The value stored under “dIS” will be shown on the display, when it matches the sensor signal defined under “InP”. The values must be parameterised in increasing order.

Parameter	Description	Setting range
dIS.1	Indication value for programmable point 1	-1999 ... 9999
InP.1	Analogue value for programmable point 1	-1999 ... 9999
dIS.2	Indication value for programmable point 2	-1999 ... 9999
InP.2	Analogue value for programmable point 2	-1999 ... 9999
dIS.3	Indication value for programmable point 3	-1999 ... 9999
InP.3	Analogue value for programmable point 3	-1999 ... 9999
dIS.4	Indication value for programmable point 4	-1999 ... 9999
InP.4	Analogue value for programmable point 4	-1999 ... 9999
dIS.5	Indication value for programmable point 5	-1999 ... 9999
InP.5	Analogue value for programmable point 5	-1999 ... 9999

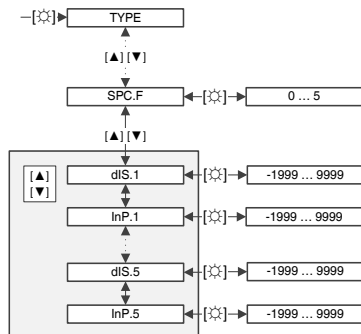

9. Frequency measurement

9.10 Menu tree

* Pflicht-Parameter

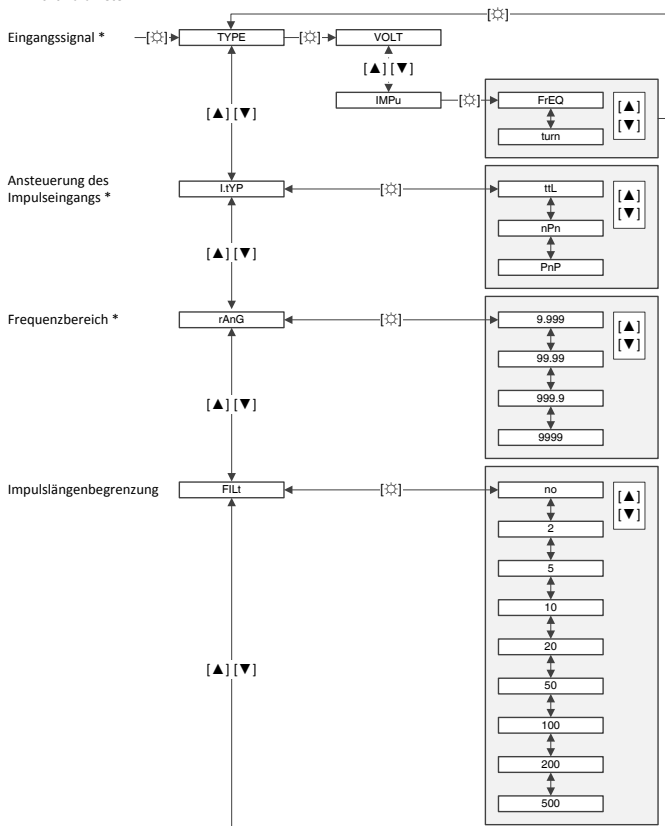

EN

9. Frequency measurement

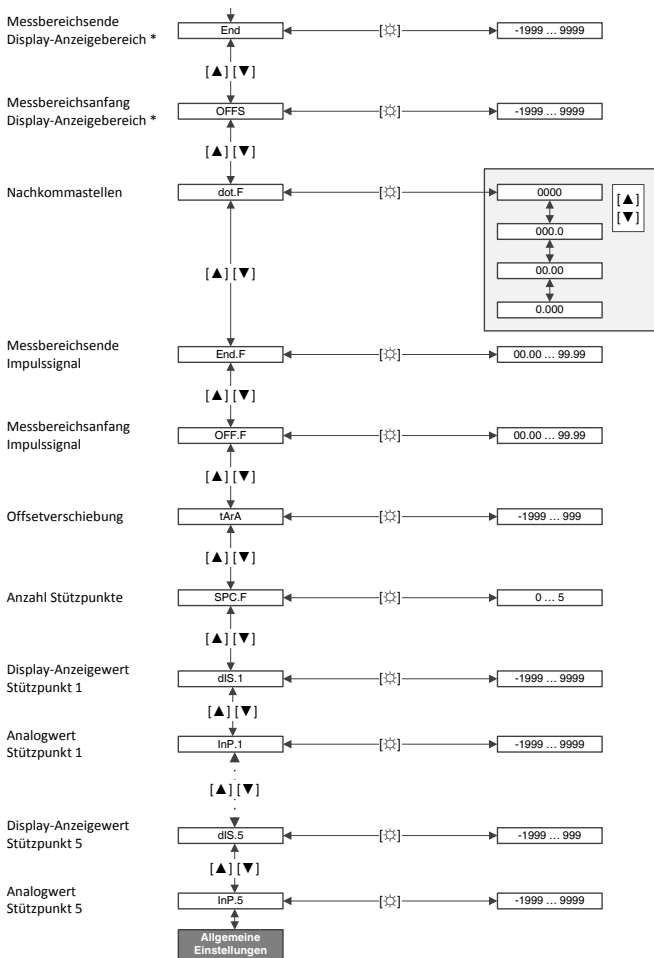

10. Rotational speed measurement

This chapter leads you through the parameters, step by step. Therefore, the sub-chapters should be worked through in sequence. Dashed lines in the diagrams indicate parameters that are skipped.

→ Complete menu tree from page 42

10.1 Selecting the input signal

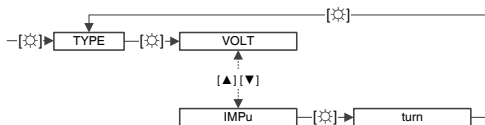

10.2 Selecting triggering of the pulse input

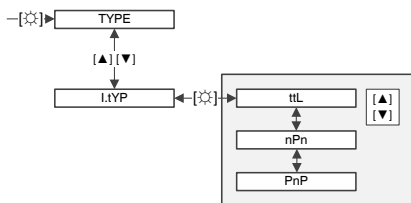

Parameter	Description
ttL	Active TTL signals 0.8 ... 2 V
nPn	Passive switch contact, which switches the internal pull-up to ground.
PnP	Active sensor output. In the indicator a pull-down is switched

10. Rotational speed measurement

10.3 Selecting pulse length limiting

Debounces mechanical contacts via the filter frequency.

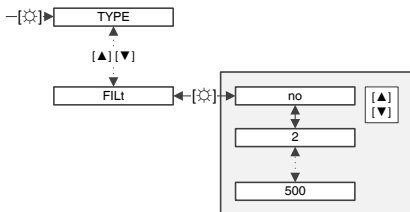

Parameter	Description
no	No evaluation of the pulse length.
2	2 Hz with a pulse-duty factor of 1:1 (minimum pulse length 250 ms)
5	5 Hz with a pulse-duty factor of 1:1 (minimum pulse length 100 ms)
10	10 Hz with a pulse-duty factor of 1:1 (minimum pulse length 50 ms)
20	20 Hz with a pulse-duty factor of 1:1 (minimum pulse length 25 ms)
50	50 Hz with a pulse-duty factor of 1:1 (minimum pulse length 10 ms)
100	100 Hz with a pulse-duty factor of 1:1 (minimum pulse length 5 ms)
500	500 Hz with a pulse-duty factor of 1:1 (minimum pulse length 1 ms)

10.4 Setting pulses per rotation

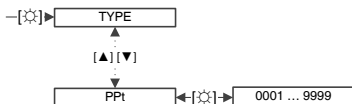

10. Rotational speed measurement

10.5 Selecting the time base

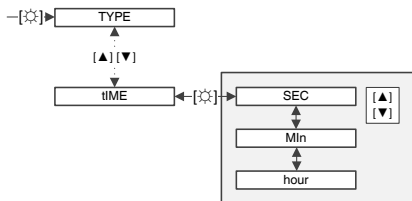

Parameter	Description
SEC	Second
Min	Minute
hour	Hour

10.6 Selecting the number of decimal places

Specifies the number of decimal places that are displayed on the screen. This parameter has no influence on the scaling of the indication value.

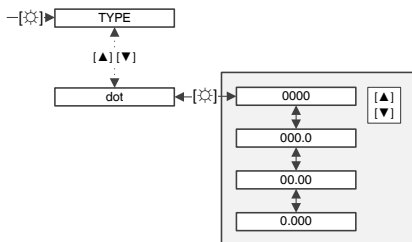

10. Rotational speed measurement

10.7 Menu tree

* Pflicht-Parameter

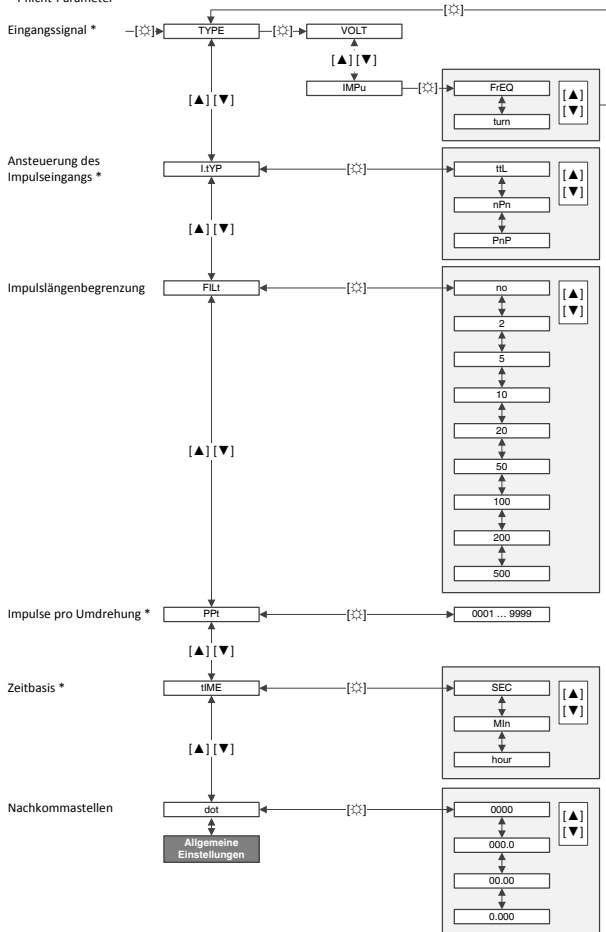

11. Up/Down counter

11. Up/Down counter

This chapter leads you through the parameters, step by step. Therefore, the sub-chapters should be worked through in sequence. Dashed lines in the diagrams indicate parameters that are skipped.

→ Complete menu tree from page 47

11.1 Selecting an up or down counter

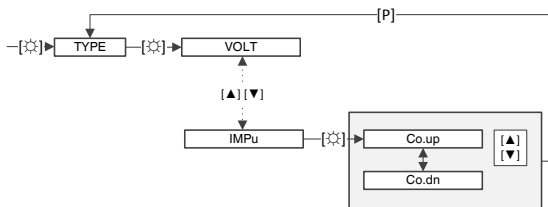

Parameter	Description
Co.up	Up counter
Co.dn	Down counter

11.2 Selecting triggering of the pulse input

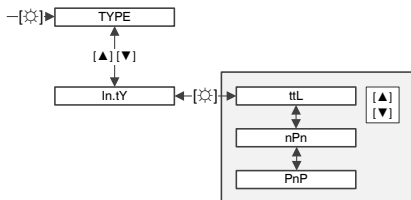

Parameter	Description
ttL	Active TTL signals 0.8 ... 2 V
nPn	Passive switch contact, which switches the internal pull-up to ground
PnP	Active sensor output. In the indicator one of the pull-downs is switched

11. Up/Down counter

11.3 Selecting the counter basis

As a basis for the counter, incoming pulses, seconds or minutes can be used. If the counter basis of seconds or minutes is used, the counting is started or stopped via the pulse input.

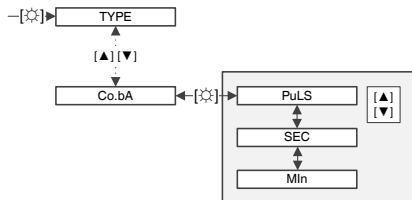

Parameter	Description
PuLS	Pulse
SEC	Seconds
MIn	Minutes

11.4 Setting the edge control

The edge control is indicated when counting.

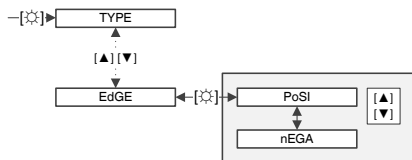

Parameter	Description
PoSI	Positive edge High signal = counter runs Low signal = counter stops
nEGA	Negative edge High signal = counter stops Low signal = counter runs

11. Up/Down counter

11.5 Setting the prescaler

For numeric values that lie outside the indication range, a prescaler can be set. The numerical value is divided by the prescaler, so that large numerical values can be scaled onto the indication range.

Example: Prescaler = 1,000

The number 5,000,000 cannot be indicated on the display. Using the prescaler, the number is divided by 1,000. On the display 5,000 will be shown.



11.6 Selecting pulse length limiting

Debounces mechanical contacts via the filter frequency.

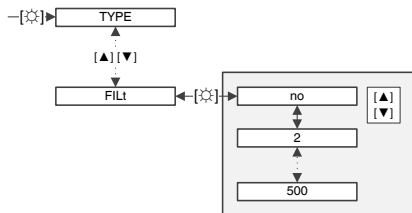

Parameter	Description
no	No evaluation of the pulse length.
2	2 Hz with a pulse-duty factor of 1:1 (minimum pulse length 250 ms)
5	5 Hz with a pulse-duty factor of 1:1 (minimum pulse length 100 ms)
10	10 Hz with a pulse-duty factor of 1:1 (minimum pulse length 50 ms)
20	20 Hz with a pulse-duty factor of 1:1 (minimum pulse length 25 ms)
50	50 Hz with a pulse-duty factor of 1:1 (minimum pulse length 10 ms)
100	100 Hz with a pulse-duty factor of 1:1 (minimum pulse length 5 ms)
500	500 Hz with a pulse-duty factor of 1:1 (minimum pulse length 1 ms)

11. Up/Down counter

11.7 Setting the upper indication value and upper pulse count value

The display is linearised freely via the prescaled pulse count. For this purpose, the number of pulses required is assigned an indication value. The zero point cannot be preselected.

EN

For the absolute counter limit values, the settings of **dl.HI** and **dl.Lo** must be used (see chapter 12 “General settings”).

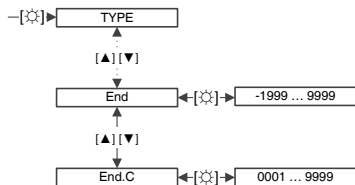

Parameter	Description	Setting range
End	Up counter: Upper indication value Down counter: Lower indication value	-1999 ... 9999
End.C	Up counter: Upper pulse count value Down counter: Lower pulse count value	0001 ... 9999

11.8 Selecting the number of decimal places

Specifies the number of decimal places that are displayed on the screen. This parameter has no influence on the scaling or the indication value.

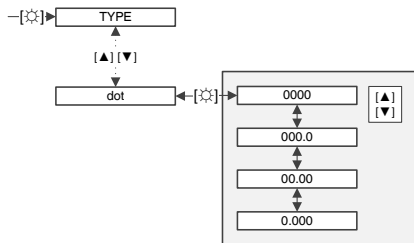

11.9 Menu tree

* Pflicht-Parameter

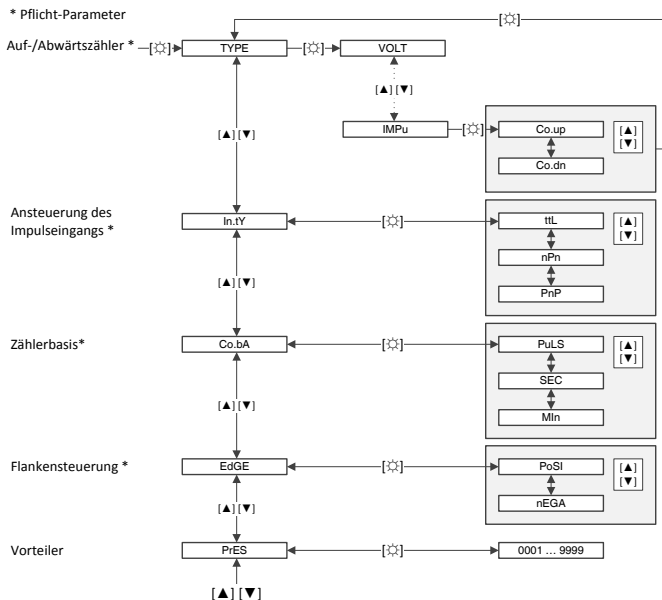

EN

11. Up/Down counter

EN

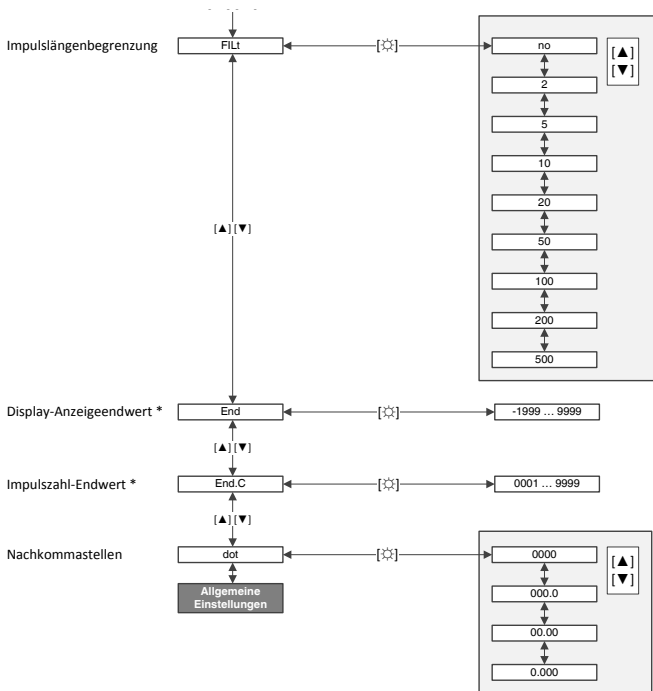

12. General settings

This chapter leads you through the parameters, step by step. Therefore, the sub-chapters should be worked through in sequence. Dashed lines in the diagrams indicate parameters that are skipped.

→ Complete menu tree from page 52

12.1 Setting the measuring time

The measuring time defines in which cycle the measured value is recorded. Via this function the display of the measured value can be settled.

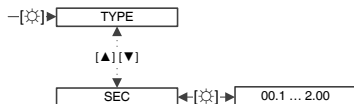

Parameter	Description
SEC	0.01 ... 2.00 seconds
	0.00 ... 2.00 seconds (with pulse measurement)

12.2 Setting the moving average determination

The display shows the moving average of the last 2 ... 20 measured values. There is no weighting of the measured values.

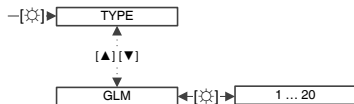

Parameter	Description
GLM	1 ... 20 (1 = moving average determination is deactivated)

12. General settings

12.3 Limiting the indication range

For overrun evaluation, the measuring range and the overrun characteristics (OVER) are evaluated. In addition, this range can be further limited using the lower indication value and the upper indication value.

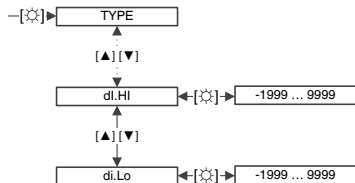

Parameter	Description	Setting range
di.HI	Upper indication value	-1999 ... 9999
di.Lo	Lower indication value	-1999 ... 9999

12.4 Assigning key functions

Here the [▲] [▼] keys can be assigned a key function.

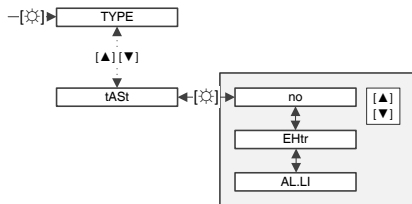

Parameter	Description
no	No function
EHtr	Retrieval of the MIN/MAX values
AL.Li	Limit value correction

12.5 Selecting display blinking

A blinking display can be set as an additional alarm function. As soon as the switching threshold is reached, the display starts to blink.

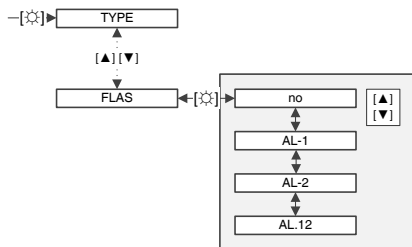

Parameter	Description
no	The display does not blink
AL-1	First limit value
AL-2	Second limit value
AL.12	Both limit values

12.6 Menu tree

EN

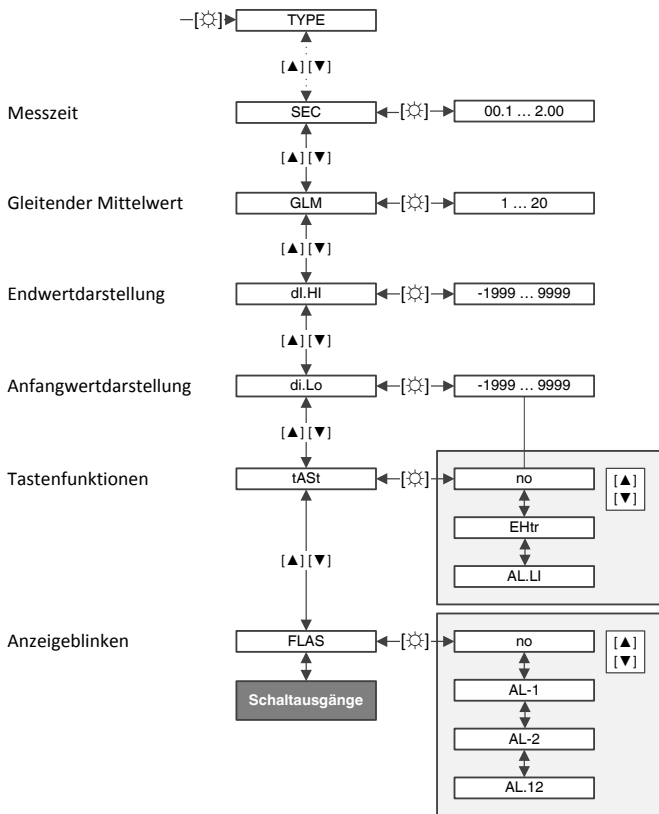

13. Switching outputs

This chapter leads you through the parameters, step by step. Therefore, the sub-chapters should be worked through in sequence. Dashed lines in the diagrams indicate parameters that are skipped.

The menu navigation is arranged in such a sequence that first switching output 1 must be set and subsequently switching output 2. In the following sub-chapters the parameters will all be described together since they behave in the same way and are carried out in the same logical sequence.

→ Complete menu tree from page 57

13.1 Selecting the switching function

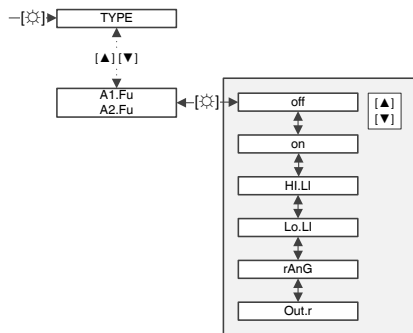

Parameter	Description
oFF	Switching output without function There are no parameters that can be set
on	The switching output is switched permanently in measuring mode Only the parameters "Ax.Er" and "Ax.tY" can be set
HI.LI	Switches when the switching threshold is exceeded
Lo.LI	Switches when measured value drops below the switching threshold
rAnG	Switches within the switching window (window function)
Out.r	Switches outside of the switching window (window function)

13. Switching outputs

13.2 Setting a switching window (window function)

These parameters are only selectable when the limit value properties “rAnG” or “Out.r” are set (see chapter 13.1 “Selecting limit value properties”).

These parameters define the upper and lower limits of the switching range.

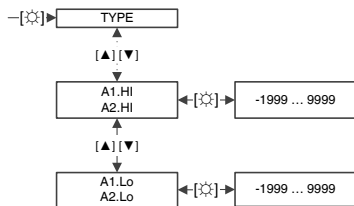

Parameter	Description	Setting range
A1.HI, A2.HI	Upper limit value	-1999 ... 9999
A1.Lo, A2.Lo	Lower limit value	-1999 ... 9999

13.3 Selecting switch behaviour for limit value errors

Sets the switch behaviour in the event an instrument checksum is incorrect or the indication range is transgressed.

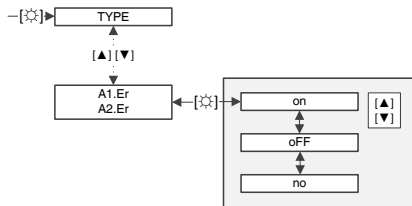

Parameter	Description
on	The selected switch behaviour is activated. In push-pull operation, HIGH/ U+ is switched.
oFF	The switching output behaviour is inverted. When an error occurs, the error behaviour overrides the actual limit value function.
no	A display overrun (> 9999) or underrun (< -1999) does not trigger any alarm.

13. Switching outputs

13.4 Selecting switch behaviour

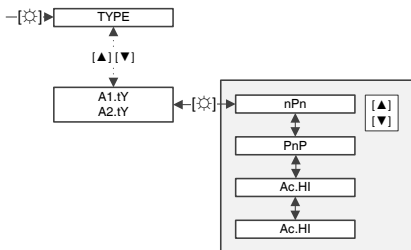

Parameter	Description
nPn	GND is through connected (low side)
PnP	U+ is through connected (high side)
Ac.HI	HIGH or U+ is through connected (push-pull)
Ac.Lo	LOW or GND is through connected (push-pull)

13.5 Setting the switching threshold

With the window function, this parameter is not requested.

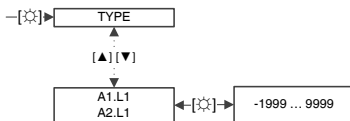

13. Switching outputs

13.6 Setting the hysteresis

The hysteresis is added to the switching threshold so that the switching of the switching output is delayed. With the window function, this parameter is not requested.

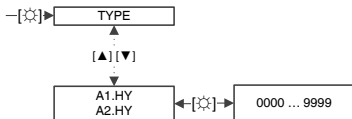

13.7 Setting the switch-off delay

The time value is reset when the instrument is restarted. On starting the instrument, the alarm status is determined directly without the set delay being taken into account.

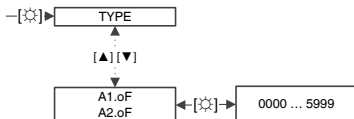

13.8 Setting the switch-on delay

The time value is reset when the instrument is restarted. On starting the instrument, the alarm status is determined directly without the set delay being taken into account.

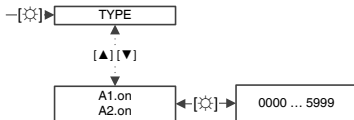

13. Switching outputs

13.9 Menu tree

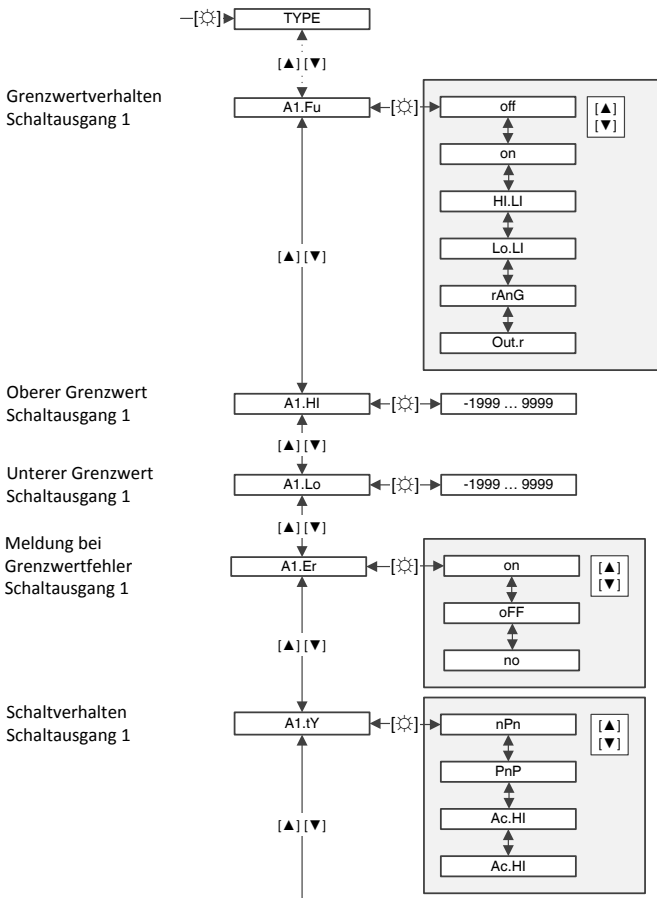

EN

14122699.02 10/2016 EN

13. Switching outputs

Schaltschwelle
Schaltausgang 1

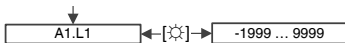

Hysterese
Schaltausgang 1



Ausschaltverzögerung
Schaltausgang 1

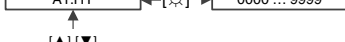

Einschaltverzögerung
Schaltausgang 1



Grenzwertverhalten
Schaltausgang 2

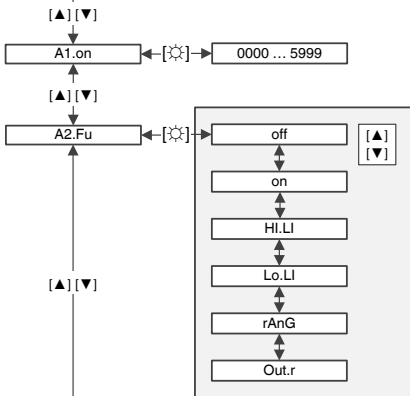

Oberer Grenzwert
Schaltausgang 2

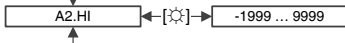

Unterer Grenzwert
Schaltausgang 2



EN

13. Switching outputs

Meldung bei
Grenzwertfehler
Schaltausgang 2

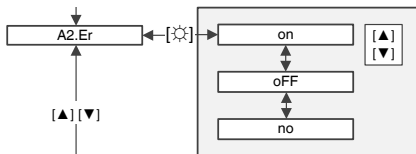

Schaltverhalten
Schaltausgang 2

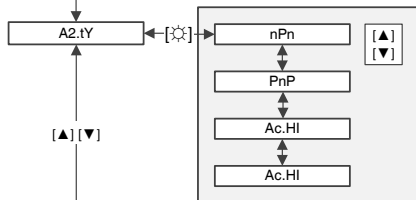

Schaltschwelle
Schaltausgang 2

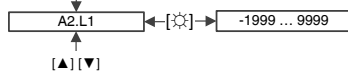

Hysterese
Schaltausgang 2

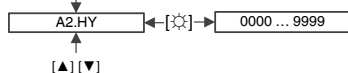

Ausschaltverzögerung
Schaltausgang 2



Einschaltverzögerung
Schaltausgang 2

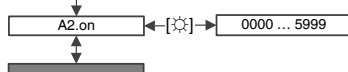

Passwortschutz

EN

14. Password protection

14.1 Setting the password

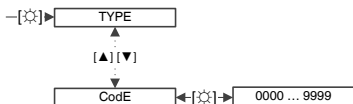

14.2 Activating/deactivating the password protection

When the password protection is activated, the keypad is locked.

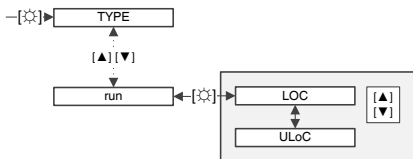

Parameter	Description
LOC	Password protection activated
ULoC	Password protection deactivated

Unlocking the keypad

1. Press the [☼] key for 3 seconds.
 - » Password entry appears.
2. Enter the password using [▲][▼] and confirm with [☼].
 - » Incorrect entry will be indicated with "FAIL".
 - » Keypad is unlocked.

14. Password protection

14.3 Menu tree

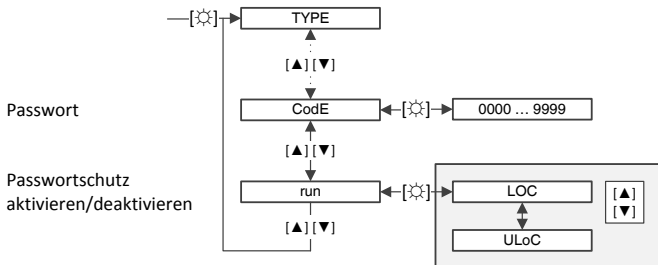

15. Factory settings



All application-specific data will be lost.

EN

With the reset, the factory settings will be loaded and used for subsequent operation.

15.1 Restoring factory settings

1. Disconnect the digital indicator from the power.
2. Hold down the [✱] key and switch on the power supply until “----” appears.
 - » The factory settings are restored.

15.2 Overview of the factory settings

Parameter	Default
A1.Er	no
A1.Fu	oFF
A1.HI	200
A1.HY	0
A1.LI	100
A1.Lo	100
A1.oF	0
A1.on	0
A1.tY	nPn
A2.Er	no
A2.Fu	oFF
A2.HI	400
A2.HY	0
A2.LI	300
A2.Lo	300
A2.oF	0
A2.on	0
A2.tY	nPn
AMPE	0 ... 20

15. Factory settings

EN

Parameter	Default
Co.bA	PuLS
CodE	1234
dI.HI	-1999
dI.Lo	9999
dot	0
dot.A	0
dot.F	0
EdGE	PoS
End	1000
End.C	1001
EndA	10
End.F	1000
FILt	no
FLAS	no
I.tYP	ttL
In.tY	ttL
OFFA	0
OFF.F	0
OFFS	0
OVER	no
PpT	1
PrES	1
Pt.SE	Pt.Lo
rAnG	9999
run	ULOC
SEC	1
SPC.A	0
SPC.F	0
tArA	0
tASt	no
tHEr	tYP.I
tIME	Min
UnIt	°C
VoIT	0 ... 10
ZErO	0

16. Faults

Faults	Causes	Measures
Permanent overrun 4 bars above	Input signal too high	Check the measuring path
	Indication range or predefined measuring range is exceeded	Check the programmable points, input types and signal range
	Not all programmable points are parameterised	Check the parameters
Permanent underrun 4 bars below	Input signal too small	Check the measuring path
	Indication range or predefined measuring range has been overrun at the low end	Check the programmable points, input types and signal range
	Not all programmable points are parameterised	Check the parameters
LBR is displayed	Cable break at the sensor, incorrect connection of the sensor (no connection to the terminal)	Check the input type
		Check the cabling
help is displayed	Error in the configuration memory	Restore factory settings
Settings for measuring input not available	Password protection active	Deactivating the password protection
Err 1 is displayed	---	Return the digital indicator to the manufacturer.
With thermocouples there are constant, higher measuring deviations	Sources of heat or cold in the direct vicinity	Remove sources of heat or cold
	Heating through high switching currents	Reduce switching current < 10 mA
	---	Correct deviations through offset shift

17. Maintenance and cleaning

17.1 Maintenance

The digital indicator is maintenance-free.

Repairs must only be carried out by the manufacturer.

17.2 Cleaning

When cleaning the front, note the following:

- The ingress protection of the front is IP 65 (protected against jet and splash water).
- Use a damp cloth.
- Do not use any aggressive cleaning agents.
- Do not use any pointed and hard objects for cleaning.

When cleaning the rear, note the following:

- The ingress protection of the rear is IP 00 (no protection).
- Disconnect the digital indicator from the power.
- Use a damp cloth. Allow the digital indicator to dry before operating it again.
- Do not use any aggressive cleaning agents.
- Do not use any pointed and hard objects for cleaning.

18. Dismounting, return and disposal

18.1 Dismounting

Digital indicator for panel mounting

1. Disconnect the digital indicator from the power.
2. Disconnect the cabling to the digital indicator or pull off the terminal blocks.
3. Loosen the clamping screws and take off the mounting elements.
4. Pull the digital indicator and seal out of the panel cutout.
5. Click the mounting elements back into place.

18.2 Return

Strictly observe the following when shipping the instrument:

All instruments delivered to WIKA must be free from any kind of hazardous substances (acids, bases, solutions, etc.).

When returning the instrument, use the original packaging or a suitable transport packaging.

To avoid damage:

1. Wrap the instrument in a plastic film.
2. Place the instrument, along with the shock-absorbent material, in the packaging.



Information on returns can be found under the heading "Service" on our local website.

18.3 Disposal

Incorrect disposal can put the environment at risk.

Dispose of instrument components and packaging materials in an environmentally compatible way and in accordance with the country-specific waste disposal regulations.

19. Specifications

Specifications

Display	
■ Principle	7-segment LED, red, 4-digit
■ Character size	10 mm
■ Indication range	-1999 ... 9999
Input	
■ Number and type	1 multi-function input
■ Input signals	Measuring ranges, resolutions, R _i see following table (Input signals) <ul style="list-style-type: none"> ■ Voltage ■ Current ■ Pt100 ■ Pt1000 ■ Thermocouple K ■ Thermocouple S ■ Thermocouple N ■ Thermocouple J ■ Thermocouple T ■ Frequency ■ Frequency, NPN ■ Frequency, PNP ■ Speed ■ Counter
■ Input configuration	Selectable via terminal connections and menu-driven programming
Switching outputs	
■ Number and type	2 semiconductor switching outputs, not galvanically isolated
■ Switch behaviour	Low side, NPN: max. DC 28 V, 100 mA High side, PNP: U ₊ - 3 V, 100 mA
Voltage supply	
■ Power supply	DC 9 ... 28 V, not galvanically isolated
■ Power consumption	≤ 1 W
Case	
■ Material	PC polycarbonate, black, UL94V-0 Sealing material: EPDM, 65 Shore, black
■ Ingress protection (per IEC 60529 / EN 60529)	Front: IP 65 Rear: IP 00
■ Weight	approx. 100 g
■ Panel cut out	45.0 ^{+0.6} x 22.2 ^{+0.3} mm
■ Mounting	Screw-type mounting brackets for wall thicknesses to 5 mm
■ Dimensions	48 x 24 x 67 mm (incl. plug-in terminal)

19. Specifications

Specifications

Operating conditions	
■ Permissible ambient conditions	Operation: -20 ... +50 °C Storage: -30 ... +70 °C
■ Humidity	0 ... 85 % r. h. annual mean without condensation
Accuracy data	
■ Measuring error	see page 77
■ Temperature drift	100 ppm/K
■ Measuring time	0.1 ... 20.0 seconds, adjustable
■ Measuring rate	approx. 1/s for temperature sensors approx. 100/s for standard signals
Memory	EEPROM, data preservation ≥ 100 years (at 25 °C)
Electrical connection	Removable plug-in terminal, 9-pin Wire cross-section up to 1.5 mm ²
CE conformity	
■ EMC directive	2004/108/EC, EN 61326-1, emission (group 1, class B) and interference immunity (industrial application)

EN

14122699.02 10/2016 EN

19. Specifications

Input signal	Measuring range	Resolution	Measuring error in % of the measuring range ¹⁾
Voltage	0 ... 10 V ($R_i > 100 \text{ k}\Omega$)	≥ 14 bit	0.2 % ± 1 digit
Voltage	0 ... 2 V ($R_i > 10 \text{ k}\Omega$)	≥ 14 bit	0.2 % ± 1 digit
Voltage	0 ... 1 V ($R_i > 10 \text{ k}\Omega$)	≥ 14 bit	0.2 % ± 1 digit
Voltage	0 ... 50 mV ($R_i > 10 \text{ k}\Omega$)		0.2 % ± 1 digit
Current	4 ... 20 mA		0.2 % ± 1 digit
Current	0 ... 20 mA		0.2 % ± 1 digit
Pt100, 3-wire	-50 ... +200 °C	0.1 °C / 0.1 °F	0.5 % ± 1 digit
Pt100, 3-wire	-200 ... +850 °C	1 °C / 1 °F	0.5 % ± 1 digit
Pt1000, 2-wire	-200 ... +850 °C	1 °C / 1 °F	0.5 % ± 1 digit
Thermocouple K	-270 ... +1,350 °C	1 °C / 1 °F	0.3 % ± 1 digit
Thermocouple S	-50 ... +1,750 °C	1 °C / 1 °F	0.3 % ± 1 digit
Thermocouple N	-270 ... +1,300 °C	1 °C / 1 °F	0.3 % ± 1 digit
Thermocouple J	-170 ... +950 °C	1 °C / 1 °F	0.3 % ± 1 digit
Thermocouple T	-270 ... +400 °C	1 °C / 1 °F	0.3 % ± 1 digit
Thermocouple R	-50 ... +1,768 °C	1 °C / 1 °F	0.3 % ± 1 digit
Thermocouple B	+80 ... +1,820 °C	1 °C / 1 °F	0.3 % ± 1 digit
Thermocouple E	-270 ... +1,000 °C	1 °C / 1 °F	0.3 % ± 1 digit
Thermocouple L	-200 ... +900 °C	1 °C / 1 °F	0.3 % ± 1 digit
Frequency	0 ... 10 kHz	0.001 Hz	
Frequency, NPN	0 ... 3 kHz	0.001 Hz	
Frequency, PNP	0 ... 1 kHz	0.001 Hz	
Speed	0 ... 9,999 1/min	0.001 1/min	
Counter	0 ... 9,999 (Prescaler up to 1,000)		

1) Measuring error valid for measuring time of 1 second



EU-Konformitätserklärung EU Declaration of Conformity

Dokument Nr.:
Document No.: 14117661.02

Wir erklären in alleiniger Verantwortung, dass die mit CE gekennzeichneten Produkte
We declare under our sole responsibility that the CE marked products

Typenbezeichnung:
Type Designation: DI32-1

Beschreibung:
Description: Digitalanzeige
Digital Indicator

gemäß gültigem Datenblatt:
according to the valid data sheet: AC 80.13

die grundlegenden Schutzanforderungen der folgenden Richtlinien erfüllen:
comply with the essential protection requirements of the directives: Harmonisierte Normen:
Harmonized standards:

2014/30/EU Elektromagnetische Verträglichkeit (EMV)
2014/30/EU *Electromagnetic Compatibility (EMC)*

EN 61326-1:2013

Unterschrift für und im Namen von / *Signed for and on behalf of*

WIKAI Alexander Wiegand SE & Co. KG

Klingenberg, 2016-06-09

Fokko Stuke, Director Operations
Electronic Products – Industrial Instrumentation

Steffen Schlesiona, Director Quality Management
Industrial Instrumentation

WIKAI Alexander Wiegand SE & Co. KG
Alexander-Wiegand-Strasse 30
63311 Klingenberg
Germany

Tel: +49 9372 132-0
Fax: +49 9372 132-406
E-Mail: info@wika.de
www.wika.de

Kommanditgesellschaft, Sitz Klingenberg –
Amtsgericht Aschaffenburg HRA 1819
Konglomerat: WIKAI Verwaltungs SE & Co. KG –
Sitz Klingenberg – Amtsgericht Aschaffenburg
HRA 4650

Komplementärin:
WIKAI International SE – Sitz Klingenberg –
Amtsgericht Aschaffenburg HRB 12505
Vorstand: Alexander Wiegand
Vorsitzender des Aufsichtsrats: Dr. Max Egl

WIKA subsidiaries worldwide can be found online at www.wika.com.



WIKAI Alexander Wiegand SE & Co. KG

Alexander-Wiegand-Straße 30

63911 Klingenberg • Germany

Tel. +49 9372 132-0

Fax+49 9372 132-406

info@wika.de

www.wika.de